



DUKERS

Quality Commercial Refrigeration



CHEF BASE

MODEL DCB48-D2









TECHNICAL SPECIFICATIONS

Voltage/Frequency 115V/60HZ
 Refrigerant R290/1.76oz
 Type of Defrost Automatic
 Interior Material 304/201 Stainless Steel
 Exterior Material 304/201 Stainless Steel
 Total Current 1.7A
 Climatic Category 4-5
 Nema Config. NEMA5-15P
 Compressor Power (HP) 1/5

TEMPERATURE RANGE (F°)	EXTERNAL DIMENSION WXDxH (INCHES)	PACKAGING DIMENSION WXDxH (INCHES)	PRODUCT NET WEIGHT	DRAWERS	40 HQ CONTAINER CERTIFICATION
33~38°F	48"x 32 1/4" x 26 5/8"	49" x 34 1/4" x 29 1/8"	180 lbs	2	66



PRODUCT FEATURES

-  Digital temperature control features a digital display to make monitoring interior temperatures a breeze. This unit also comes with an auto-defrost function.
-  Foamed-in-place insulation keeps the interior cold and adds structural strength.
-  Stainless steel Interior with rounded corner for easy cleaning. Meet and exceed sanitation standards.
-  Drawers hold 4" deep food pans (not included) with heavy-duty, high-capacity slide rails.
-  Heavy-duty 4" casters with brakes are included providing the unit with convenient mobility, making cleaning and servicing a breeze! Just roll the unit away from the wall.
-  Ergonomic and modern recess door handles, durable and high weight bearing rails
-  Removable Drawer Gaskets, each drawer gasket is removable for easy cleaning and maintenance.



HIGH QUALITY STAINLESS STEEL & ROBUST DESIGN



Los Angeles | San Francisco | Dallas
Houston | Florida | Chicago | New Jersey

1-800-931-8628

@ info@dukersusa.com

www.DukersUSA.com

DETAILS & SPECIFICATIONS

CHEF BASE

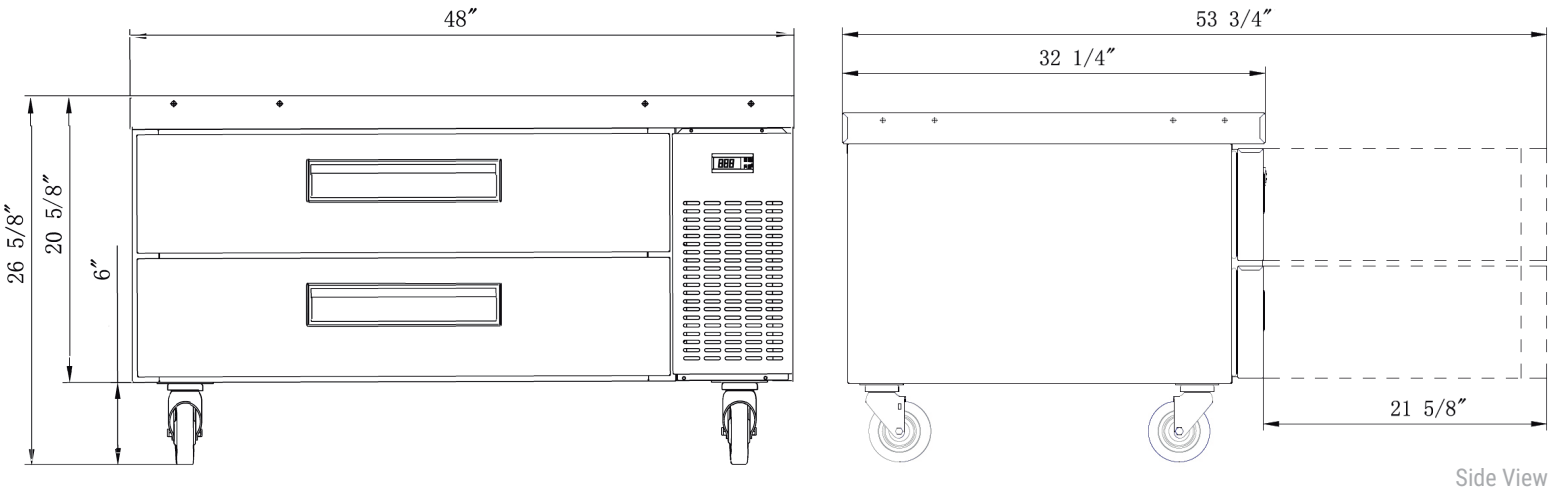

Side View

MODEL DCB48-D2

Rated Voltage	115V
Rated Frequency	60Hz
Total Input Power	200W
Total Current	1.7A
Climatic Category	4-5
Protection Type	I
Design Pressure High Side	300 PIG
Design Pressure Low Side	150 PIG
Insulation Blowing Gas	C-Pentane
Net Weight	180 lbs
Nema Config.	NEMA5-15P
Temperature Range	33~38°F
Heating Power	192.9W
40 HQ Container Certification	66
Refrigerant	R290/1.76 oz
1/6 Pan Count	15
Compressor Power (HP)	1/5

Pan Layout

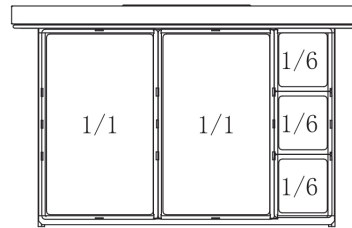

FULL PANS

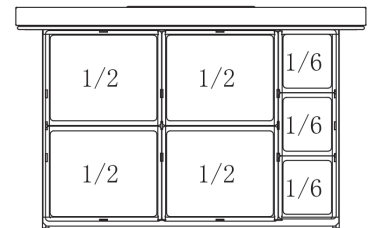

HALF PANS

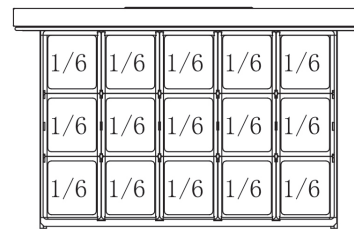

SIXTH PANS



Los Angeles | San Francisco | Dallas
Houston | Florida | Chicago | New Jersey

1-800-931-8628

@ info@dukersusa.com

www.DukersUSA.com