



**DIM-150 / 300**

# ICE MAKER



—DIM-150 / 300—

## Technical Specifications

Rated Voltage	<b>115V / 60Hz</b>
Ambient Temperature Range	<b>35°F - 110°F</b>
Water Temperature Range	<b>38°F - 90°F</b>
Potable Water Pressure	<b>138kPa-550kPa</b>
Refrigerant	<b>R290</b>
Fuse Rating	<b>10A</b>



M: Cube  
 Weight: 11g  
 Water content: 2%  
 Size: 7/8" x 7/8" x 7/8"

## Features & Benefits

- Stainless steel interior and exterior, floors and rounded cabinet corners for easy cleaning.
- It remains fully operational at peak ambient air temperatures up to 110°F.
- Incorporates R290 / R410A refrigerant, which offers higher efficiency and is more environmentally friendly with a lower global warming potential.
- Equipped with an intelligent controller for automatic ice making and ice release. Features a uniquely designed evaporator for more efficient cleaning and includes a fault alarm system.
- All plastic interior plus 100% antimicrobial plastic liner.
- For cleaning, pour the cleaning solution into the water trough. The cleaning process requires approximately 35 minutes to complete.
- Designed for easy repair and maintenance, featuring removable air filter, water trough, and distribution tube for quick and efficient cleaning.
- Ideal for hotels, restaurants, coffee shops, convenience stores, beverage shops, and more—providing rapid cooling for drinks.



Los Angeles | San Francisco | Dallas | Houston |  
 Florida | Chicago | New Jersey | Colorado | Georgia

 1-800-931-8628  
 [info@dukersusa.com](mailto:info@dukersusa.com)  
[www.DukersUSA.com](http://www.DukersUSA.com)

# ICE MAKER

## -DIM-150 / 300-

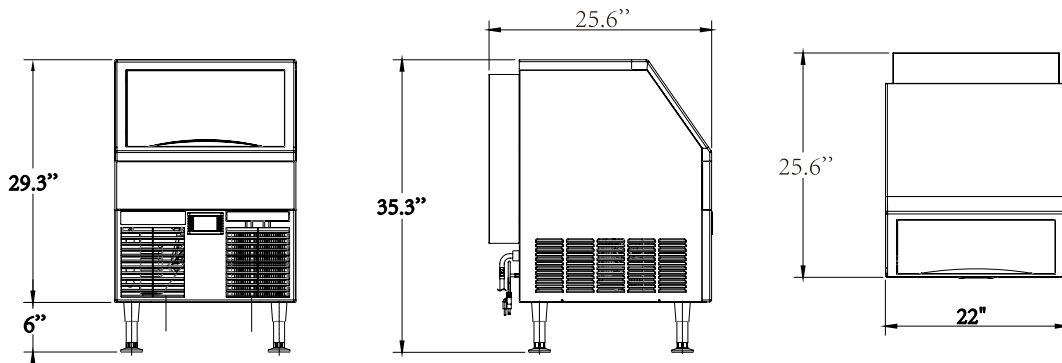

-DIM-150-

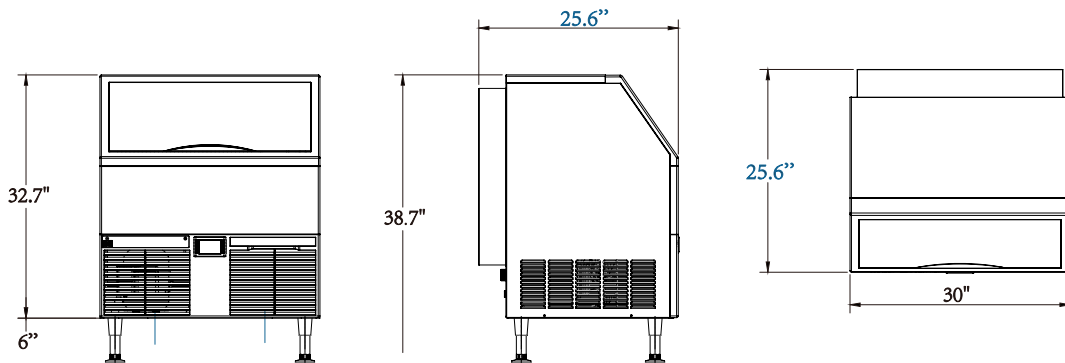

-DIM-300-

Model	External Dimensions (inches)			Packing Dimensions (inches)			Ice Type	Ice Production 24 Hours (Air/Water)		Power Usage (Kwh/100lbs)	Potable Water (Usage/100lbs)	Net Weight (lbs)	Gross Weight (lbs)	Rated Power	Rated Current	BTU Per Hour	NEMA Config.	Bin Storage (lbs)
	W	D	H	W	D	H		70 air / 50 water	90 air / 70 water									
DIM-150	22	25.6	35.3	25.98	28.35	36.22	Cube	156 lbs	137lbs	5.6	54L	100.1	110.5	360W	1.6A	2000(Average) 2500(Peak)	5-15P	40
DIM-300	30		38.7	32.28	29.53	39.37		312 lbs	278 lbs	5.3	53L	127.9	154.3	680W	3A	3000(Average) 3800(Peak)		88



NEMA-5-15P



Los Angeles | San Francisco | Dallas | Houston |  
Florida | Chicago | New Jersey | Colorado | Georgia

1-800-931-8628  
info@dukersusa.com  
www.DukersUSA.com