



DUKERS

Quality Commercial Refrigeration



UNDERCOUNTER REFRIGERATOR

MODEL DUC36R
2-Door



PRODUCT FEATURES

- The back mount compressor structure is placed in the coolest possible area, provides quick and easy service.
- Digital temperature controls with LED display for precise adjustment and automatic defrosting system.
- Higher Resistance to dust, high quality condenser.
- R290 Natural Refrigerant, promotes faster cool down and efficient energy consumption
- Stainless steel inside and outside, sealed interior floors and rounder cabinet corners for easy cleaning.
- Includes 1 adjustable and removable wire shelf.
- Lifetime warranty on hinges.
- 2 locking casters (5").



TECHNICAL SPECIFICATIONS

Voltage/Frequency	110V/60Hz
Refrigerant	R290
Type of Defrost	Automatic
Interior Material	Stainless Steel
Exterior Material	Stainless Steel
Temperature Range °F	33 ~ 41°F
Compressor Power (HP)	1/5
Nema Config.	NEMA5-15P



HIGH QUALITY STAINLESS STEEL & ROBUST DESIGN



DUKERS

Los Angeles | San Francisco | Dallas
Houston | Florida | Chicago | New Jersey

1-800-931-8628

@ info@dukersusa.com

www.DukersUSA.com

DETAILS & SPECIFICATIONS

UNDERCOUNTER DUC36R

Front View

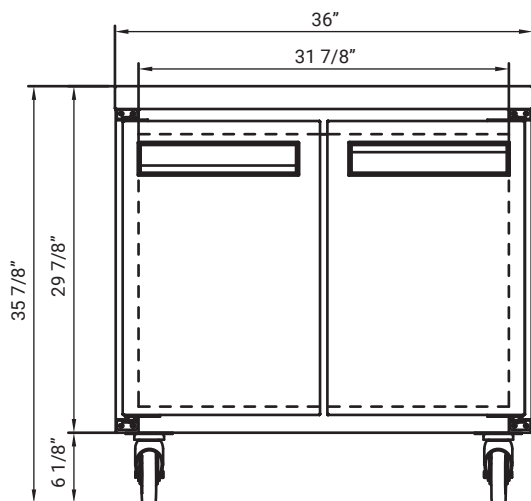

Side View

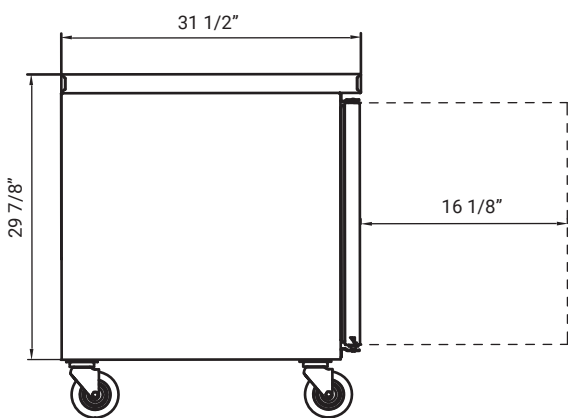

MODEL DUC36R

Rated Voltage	110V
Rated Frequency	60Hz
Total Capacity	9.6 cu ft
Insulation Blowing Gas	C-Pentane
Refrigerant	R290/3.17oz

MODEL	EXTERNAL DIMENSION WXDXH (INCHES)	PACKAGING DIMENSION WXDXH (INCHES)	PRODUCT NET WEIGHT	# OF SHELVES	40HQ CONTAINER CERT.
DUC36R	36 x 31 1/2 x 36	37 3/8 x 33 1/8 x 39 3/8	184 lbs	2	46



Los Angeles | San Francisco | Dallas
Houston | Florida | Chicago | New Jersey

1-800-931-8628

info@dukersusa.com

www.DukersUSA.com